



Beverages



Paper



Notebooks



Trays

SAFE WRAP

your products to make sure they reach customers safely



- ✓ Increases brand awareness & loyalty
- ✓ Eliminates use of carton boxes
- ✓ Fast and stable production
- ✓ Man power saving



REAM PACKING & BUNDLING LINE

The Italindia Packplus Automatic Shrink Packaging Line (Ream Packing and Bundling line) is designed to pack individual reams using LDPE film with **four side seal** and then stack them into bundles. The bundles are manually wrapped with HDPE fabric with aid of wrapping sheet dispenser. The wrapped bundles are again wrapped in shrink film, sealed on all sides and shrunk by a shrink tunnel and delivered.

The entire line can be grouped into three segments based on the function

- Ream packing
- Bundle stacking & wrapping station
- Bundle shrink wrapping line



Ream Packing Station



REAM PACKING & BUNDLING LINE



Bundle Stacking & Wrapping Station

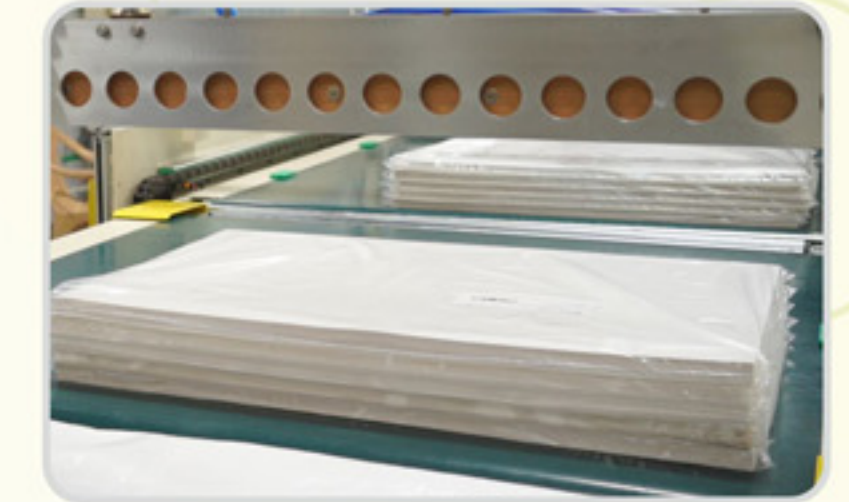

Four sides sealed reams

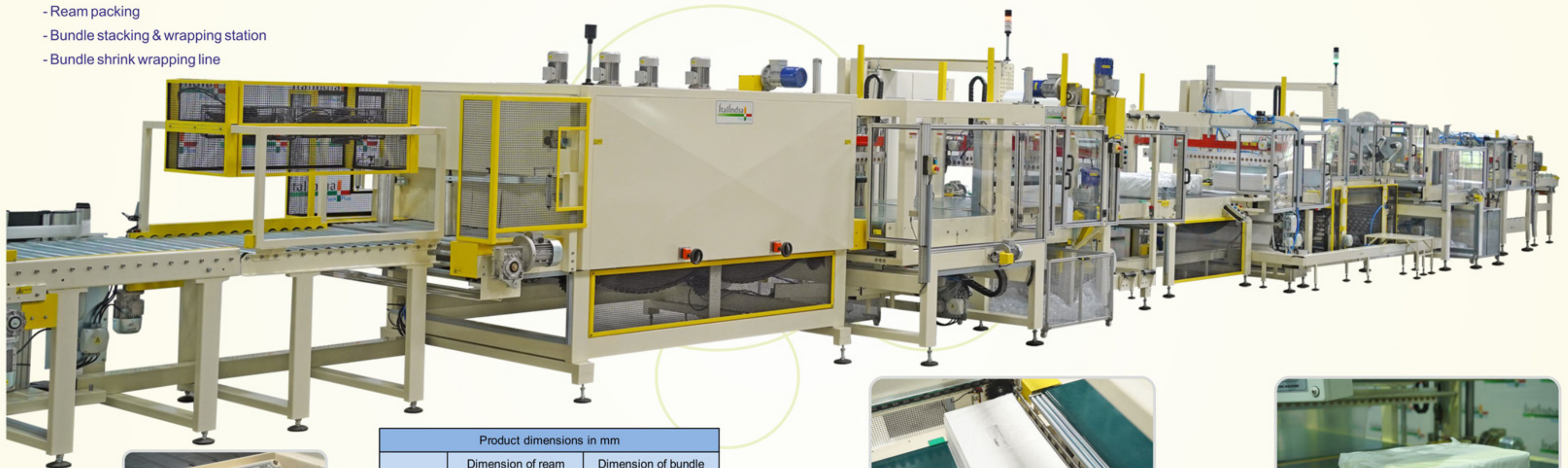

Push button station

Product dimensions in mm				
	Dimension of ream		Dimension of bundle	
	Min.	Max.	Min.	Max.
A	300	1050	300	1050
B	460	1050	460	1050
H	10	30	55	300

Note: $B + 2H = \text{Max. } 1500\text{mm}$
For closed side face by overlapping of film

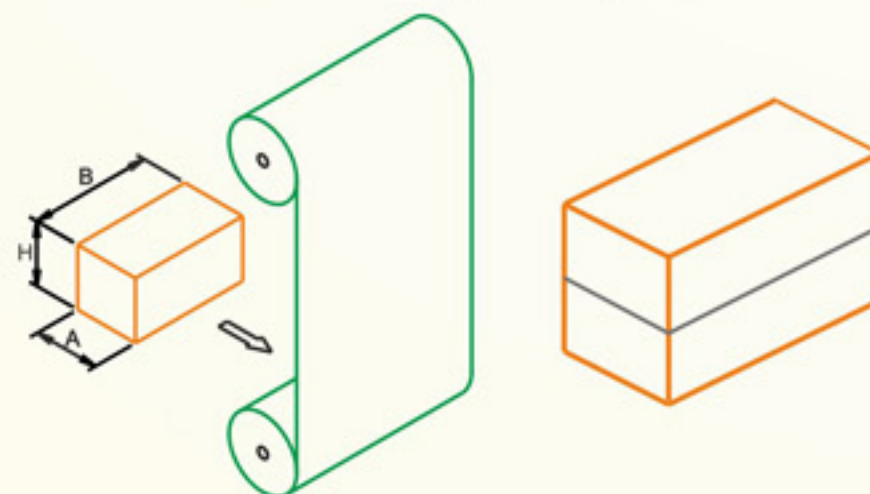

Stacked reams



Stacked reams wrapped with HDPE sheet



Bundle Shrink Wrapping Station



Finished Shrink wrapped bundles

Characteristics of Polyethylene Film Roll

Min. Bobbin diameter	70 mm
Max. Bobbin diameter	300 mm
Max. Bobbin width for Ream packing film	1200 mm
Max. Bobbin width for Bundle packing film	1500 mm
Min. Film thickness	30 μ
Max. Film thickness	120 μ



TR12-15-20-25

(For big size products)



Model: TR15



Two reels shrink wrapping machines for the packaging of large industrial products using PE film.

Packages can be sleeve wrapped or totally closed by overlapping the film on the sides and melting it while passing into the shrink tunnel. The hot air inside the **shrink tunnel can be fully set-up** according to the size of the product **to obtain a perfect shrink result.**

With these models, **large size products can be packed quickly and easily**, otherwise it would be difficult or takes more time to package them manually. The top quality final package features strong sealing and **guarantees a very good protection to the product until the end user.**

These machines are particularly suitable to pack and shrink products like wooden or metal furniture, plastic, wooden or insulation panels, doors, chairs, products for garden, radiators, bed frames and several large products.

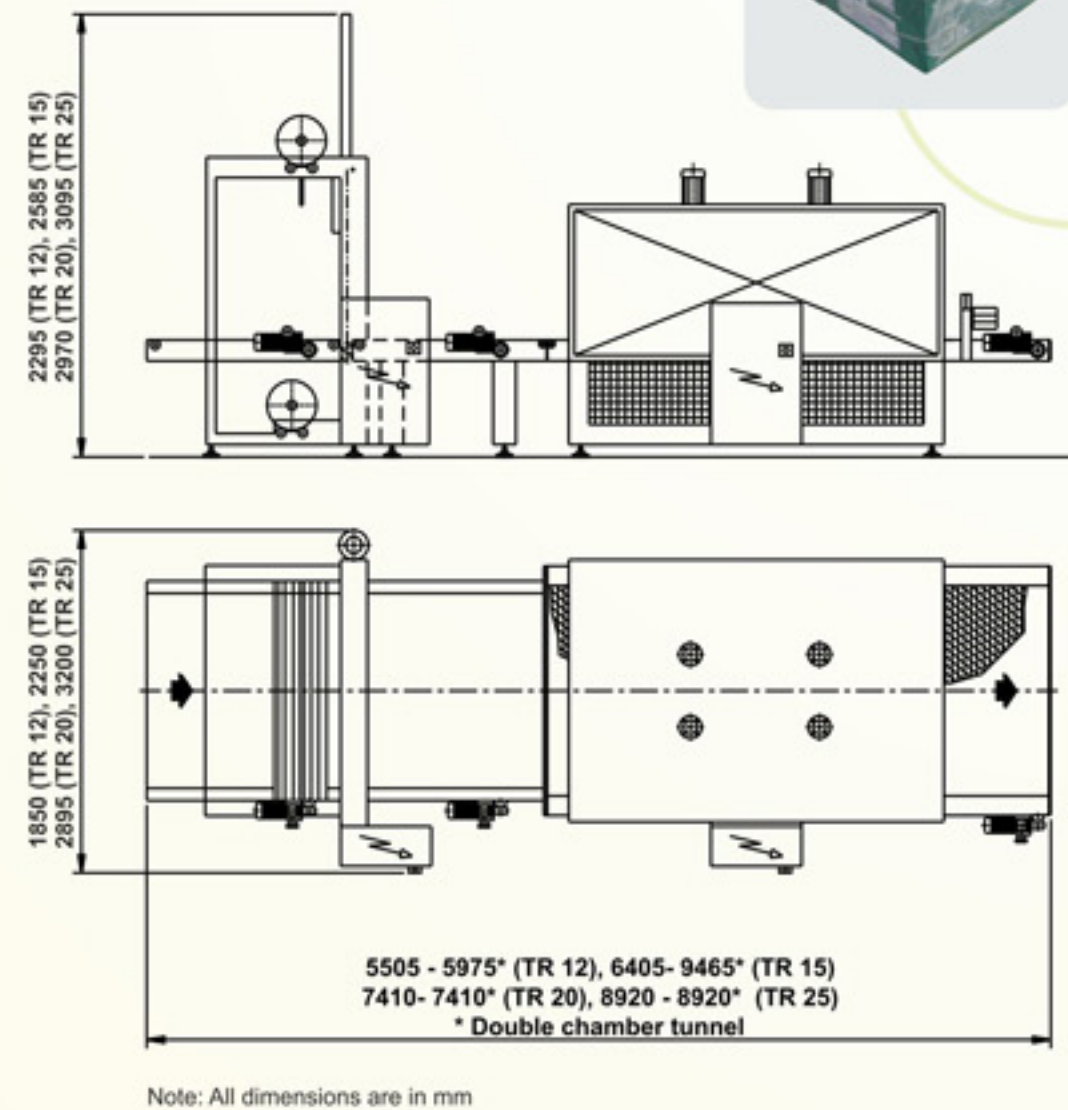

SHRINK WRAPPING MACHINES

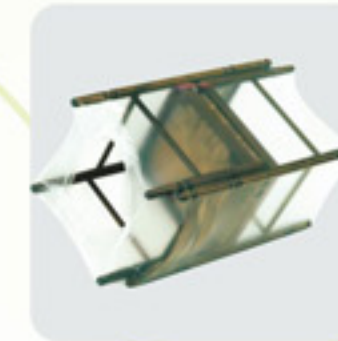
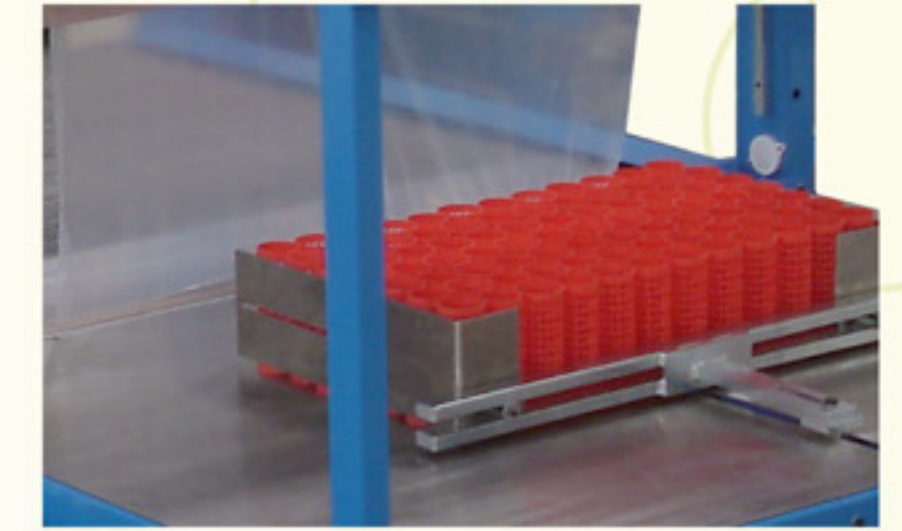
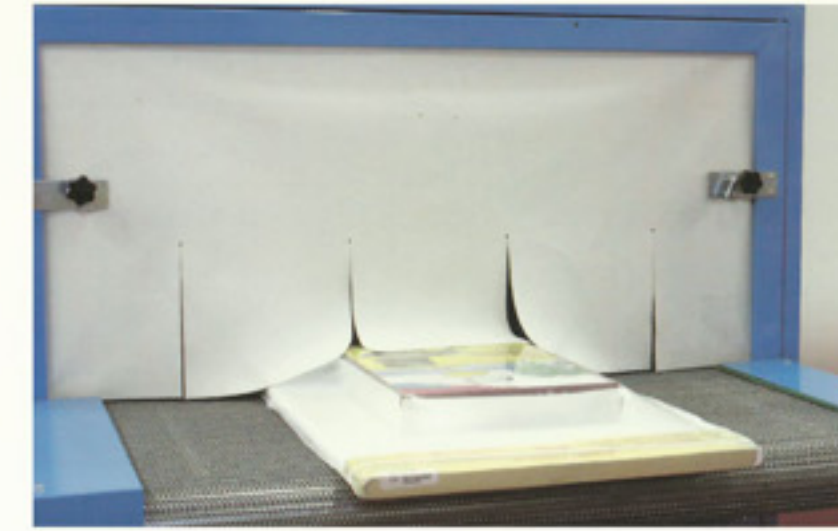

	TR 12	TR 15	TR 20	TR 25
Max. Ø of film reel (mm)	350	350	350	350
Film thickness (µ)	30 - 110 (PE)	30 - 110 (PE)	30 - 110 (PE)	30 - 110 (PE)
Installed Power (kW)				
Machine + Standard tunnel (or Double chamber tunnel)	3 + 38 (55)	3 + 54 (74.5)	5 + 54 (87.5)	5.5 + 62 (100)
Belt speed (m/min.)				
Standard tunnel	2.5 - 12	2.5 - 12	2.5 - 12	2.5 - 7
Double chamber tunnel	2.5 - 15	2.5 - 15	2.5 - 15	2.5 - 14
Packing Dimensions (mm)				
Min. A x B x H	400 x 100 x 50	400 x 100 x 50	400 x 100 x 50	400 x 100 x 50
Max. A x B x H	1200 x 1000 x 400	1200 x 1300 x 500	1400 x 1500 x 500	1600 x 2100 x 500
Max. B + H	1200	1500	2000	2500

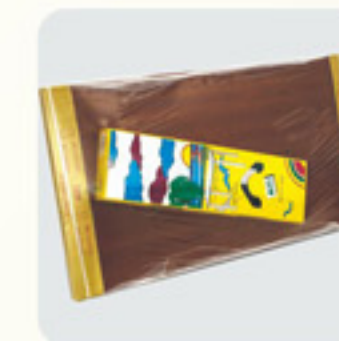

Product dimensions:

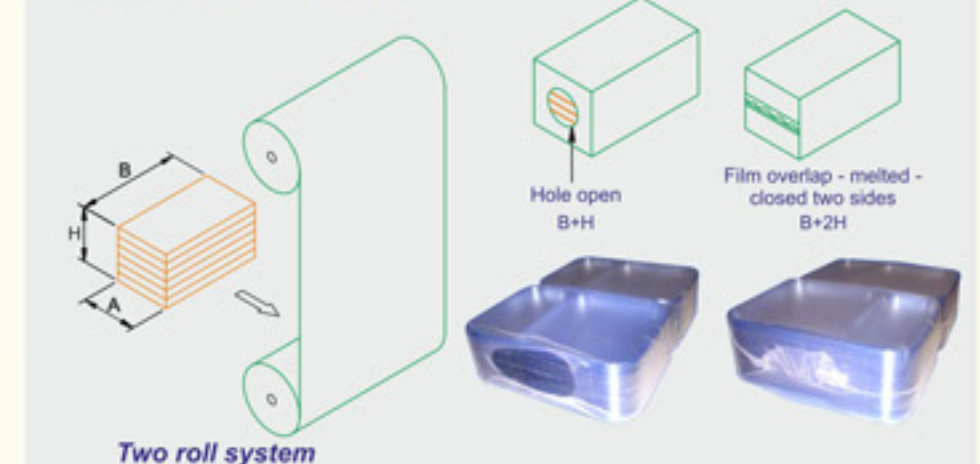



TR8 / TR10 SERIES

TR8 / TR10 is a very flexible model suitable for products of different sizes and guarantees **high efficiency in the packaging process** to your company. TR8 / TR10 offers **top quality packages** both in the sealing strength and shrinking processes **to protect your products** during transports (the heat shrink polyethylene film can be used to replace expensive carton packages and it can also be printed with your brand name)

The model TR8 / TR10 packages products of different sizes and collations with polyethylene film. It uses two polyethylene film reels and it is equipped with a feeding system which groups and places the products in the wrapping area, a sealing bar, a motorized conveyor to put the products in the shrink tunnel automatically.

Model: TR8 SA

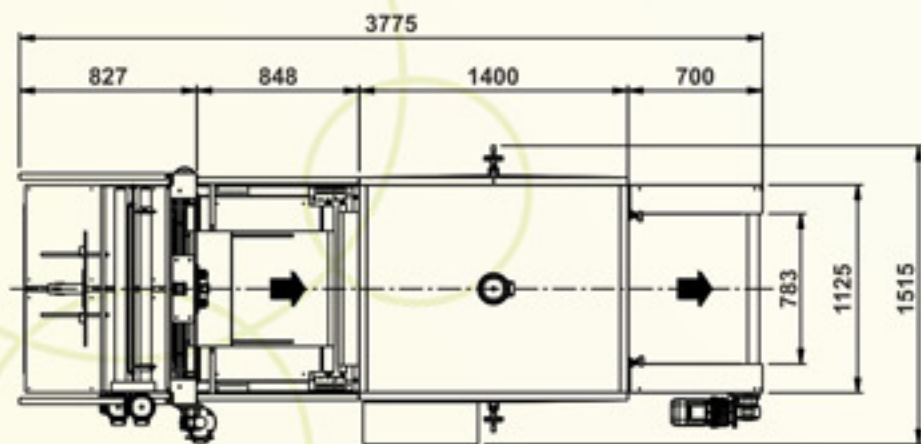

Note: All dimensions are in mm

Layout: TR8 SA



Model: TR8 A90° MT (Multitrack)

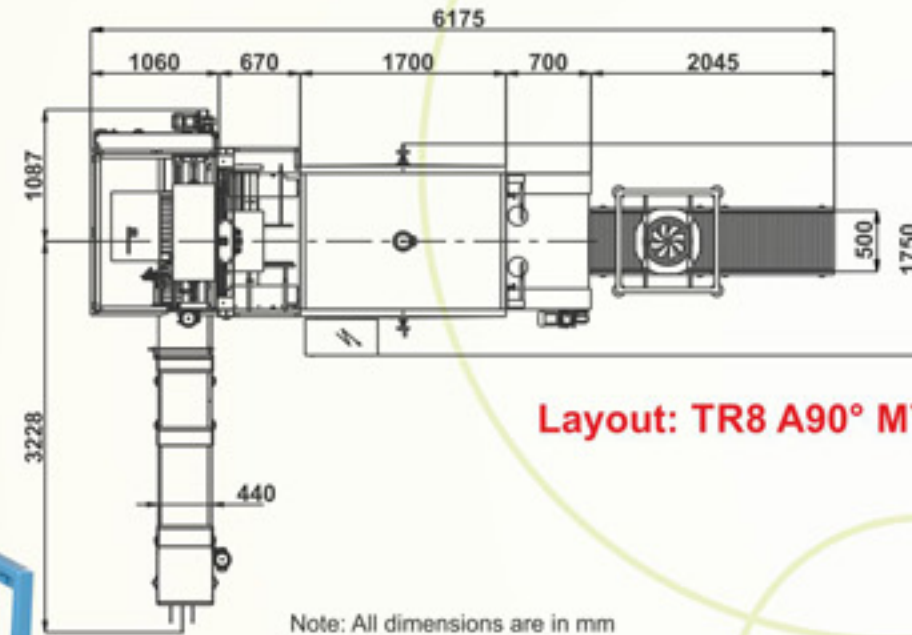

Layout: TR8 A90° MT

Note: All dimensions are in mm

The TR8 series is available in four different and TR10 series is available in three different configurations according to the feeding requirements and customer needs. All machines are modular so that the feeding system can be upgraded without changing the entire machine.



SHRINK WRAPPING MACHINES

Semi-Automatic - TR8 SA

This is the basic model of TR Series. The product loading is manual and the wrapping and shrinking processes are automatic. The machine is activated with a pneumatic pushing system



Automatic - TR8 A

The product is automatically detected and loaded with a frontal driven feeding belt. It allows to connect directly this packaging machine to the production line or to allow the manual loading very quickly for single item products.



Automatic - TR8 A 90°

Products are loaded with a 90° conveyor and then automatically collated according to the required collation of bundle. This model completely automates the collation process to offer a high production output.



Kissing Belt - TR8 L

As in TR8A the product is loaded with a frontal motorized conveyor, but also a special Kissing Belt system allows light and unstable products to travel over the sealing system without falling or catching in the machine. (picture A & B)



	TR8 A	TR8 SA	TR8 A 90°	TR 8L	TR 10 SA	TR 10 A	TR10 A 90°
Max. Ø of film reel (mm)	350	350	350	350	350	350	350
Film thickness (µ)	30 - 110 (PE)	30 - 110 (PE)	30 - 110 (PE)	30 - 110 (PE)	30 - 110 (PE)	30 - 110 (PE)	30 - 110 (PE)
Installed Power (kW) Machine + Standard tunnel	20	20	20	20	24	27.5	27
Packing dimensions (mm)							
Min. A x B x H	250 x 100 x 50	70 x 150 x 5	70 x 200 x 70	200 x 100 x 50	70 x 150 x 5	250 x 100 x 50	100 x 200 x 80
Max. A x B x H	350 x 580 x 370	350 x 600 x 370	300 x 500 x 370	750 x 580 x 260	350 x 800 x 370	900 x 800 x 370	300 x 600 x 370
Max. B + H	800	800	800	800	1000	1000	1000



Product dimensions:

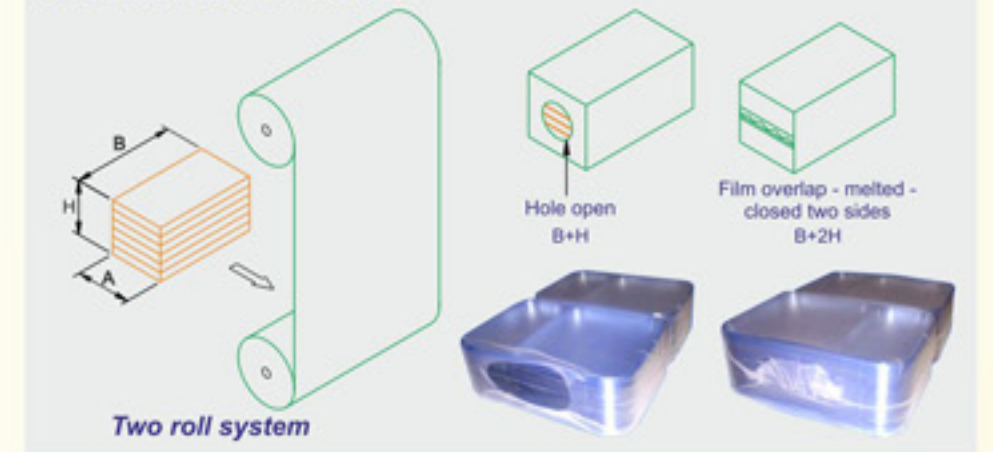



Model: TR10 A90° MT

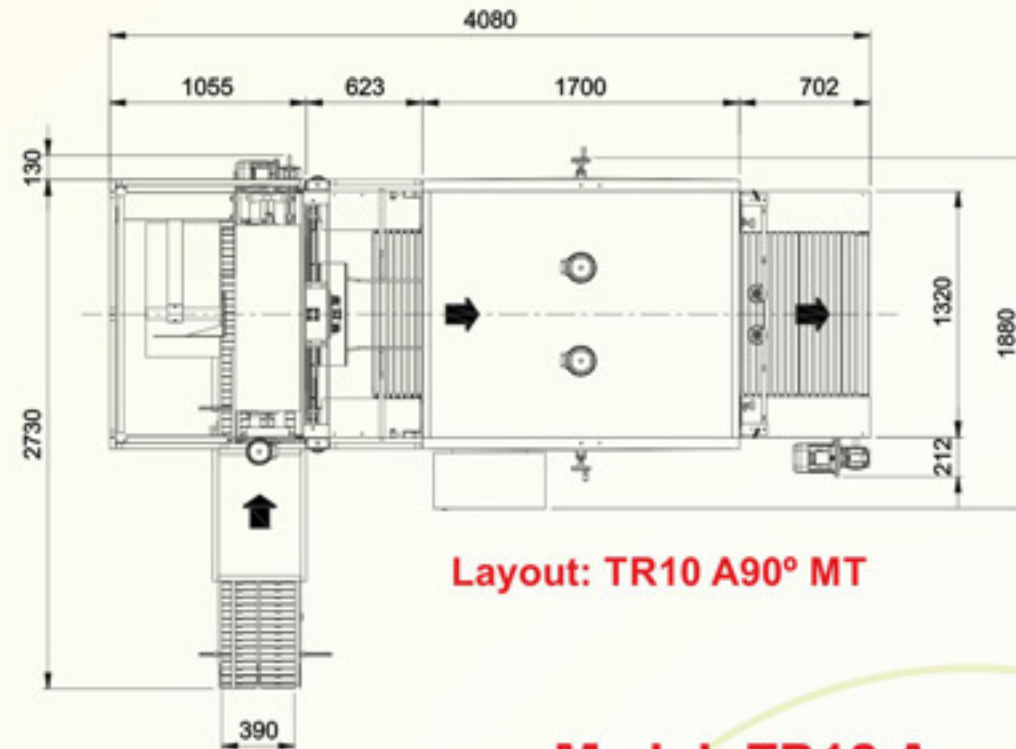

Note: All dimensions are in mm

Model: TR10 A

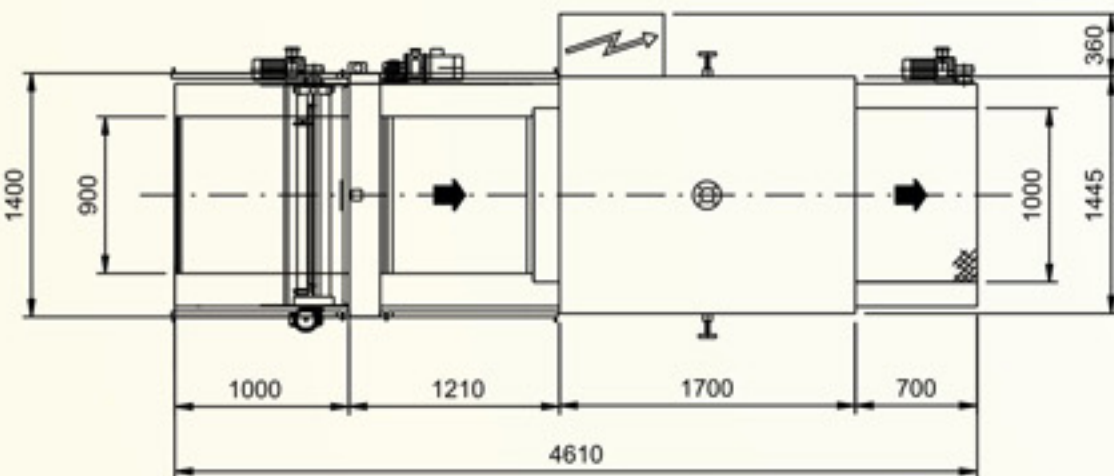

Note: All dimensions are in mm

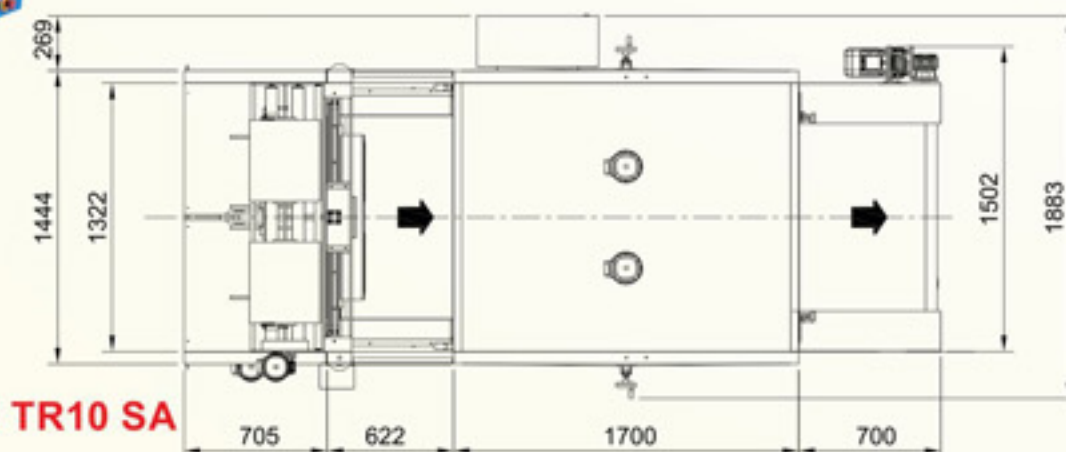

Note: All dimensions are in mm



CASE ERECTOR



The vertical semi-automatic Case erector is highly flexible and easy to operate. It is equipped with case forming and case taping units, reducing operator time by up to 50%.

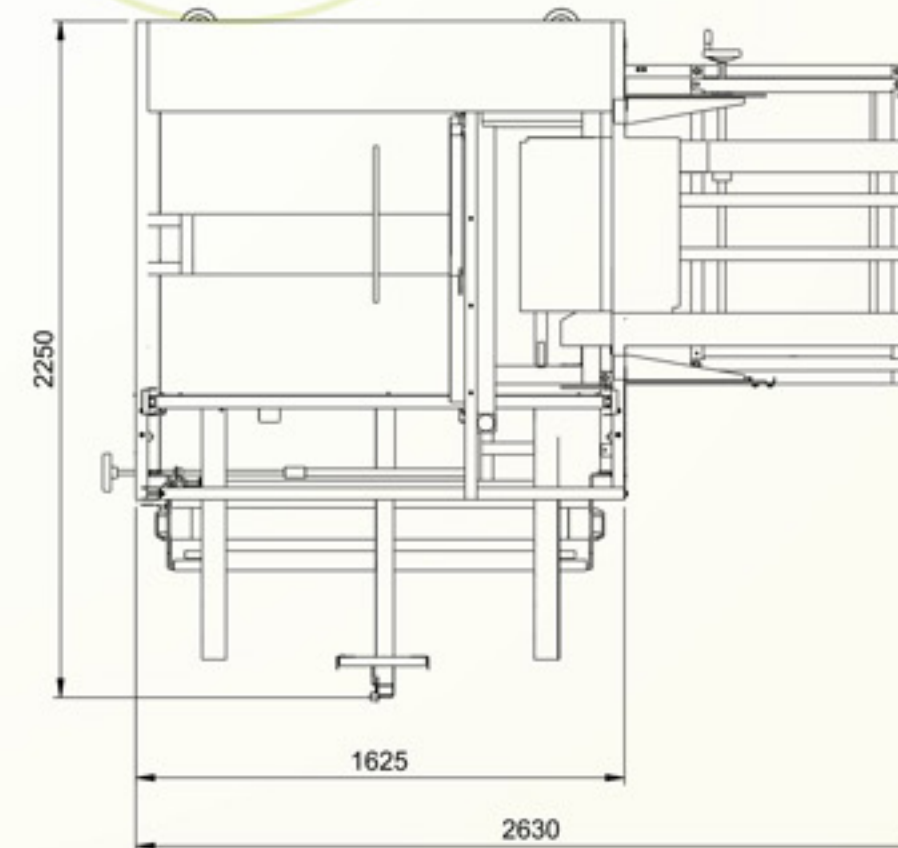
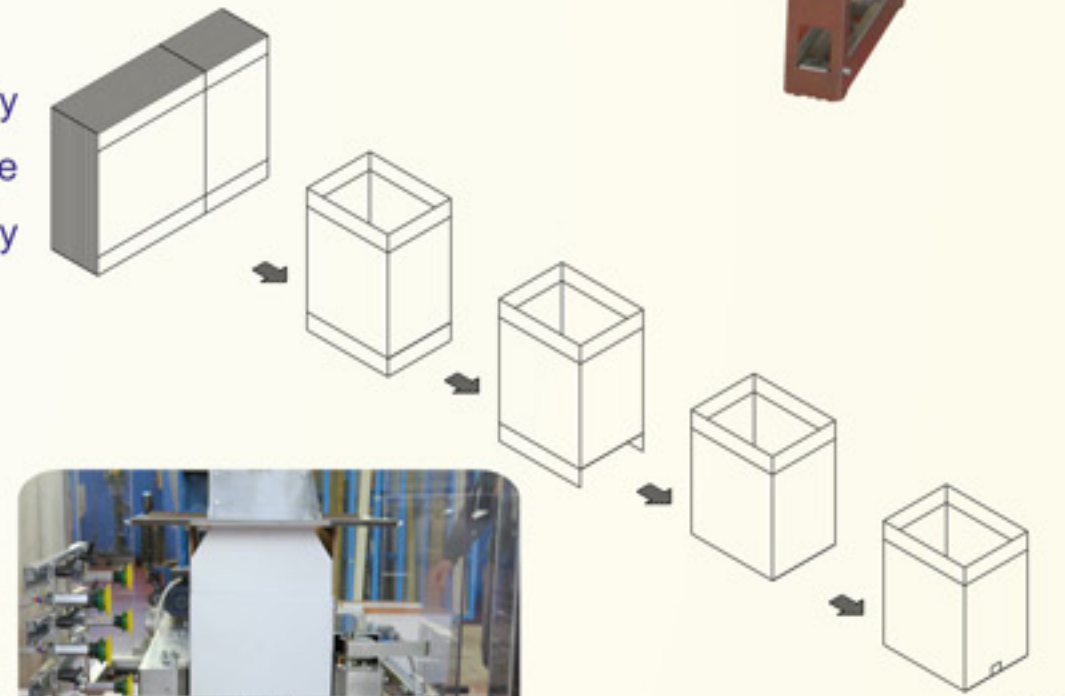

Note: All dimensions are in mm

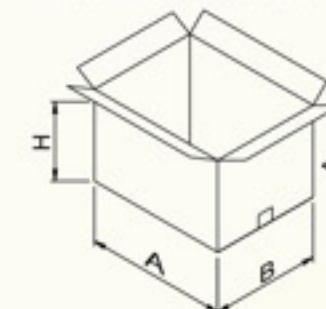

Product Dimensions in mm

	Min.	Max.
A	250	600
B	250	500
H	250	500

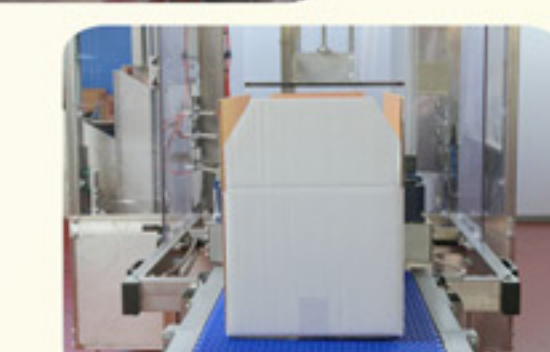

Model: TR10 SA

Layout: TR10 SA



SALLY 5-8-12



Model: SALLY 5 High Speed

The Sally model is a **total enclosure automatic packaging machine** with continuous side sealing system.

The machine is available in **Polyethylene film version to fully protect the products** or in **Polypropylene shrink film version to give an aesthetic appearance to the products for supermarkets**. The machine can run also with printed film and if combined to the shrink tunnel it can produce a totally shrunk and tight pack.

Sizes and speeds are easily adjusted using hand wheels with counter indicators. The length of the product is automatically detected and products can be upto 6 meters long or for packing **mixed products of different lengths** when fed.

It is equipped with motorized conveyors featuring variable speed, lengthwise sealing bar, continuous side sealer, trim waste collection system and touch screen control panel to check the daily production and to set up different parameters.

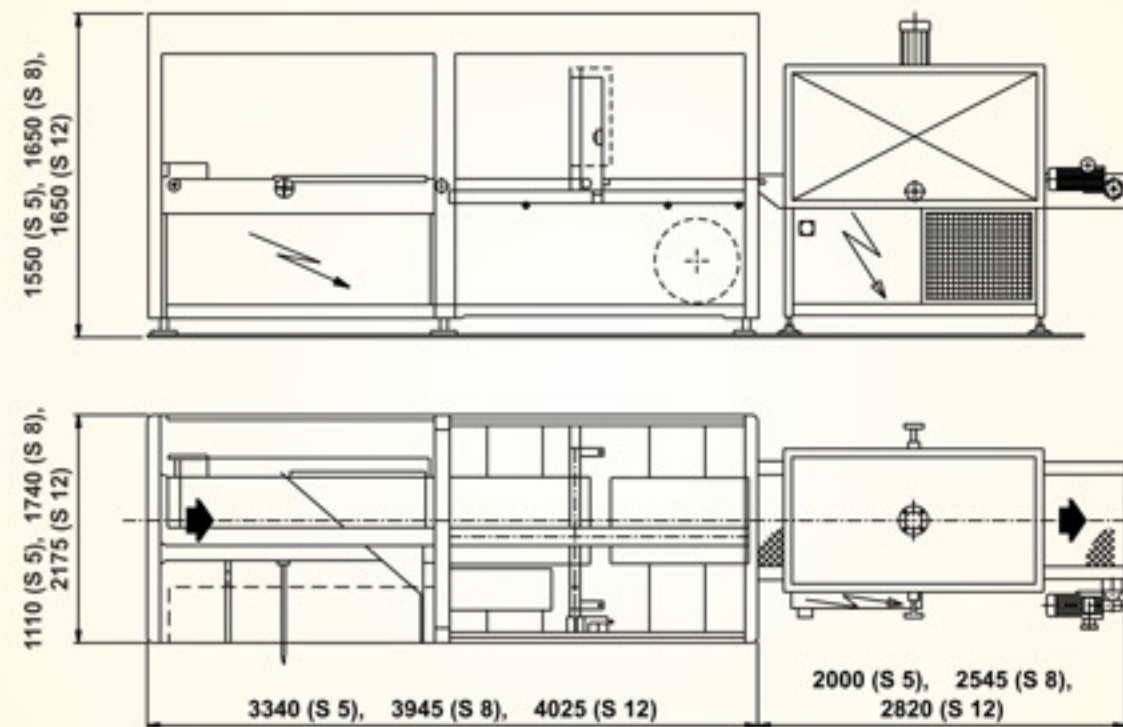

Note: All dimensions are in mm



SHRINK WRAPPING MACHINES



Model: SALLY 5

SPECIFICATIONS	Sally 5	Sally 8	Sally 12	Sally 5 / HS
Compressed air consumption (6 bars)	30 NI / cycle (P.P)		70 NI / cycle (P.E)	
Product weight (Max.)	10 Kg/m (Special high weight version available)			
Max. Ø of film reel	350 mm			
Film thickness	11 - 25 µ (P.P)		26 - 60 µ (P.E)	
Belt speed	Depending on film type (P.E - P.P)			
Standard tunnel	8 - 15 m/min.		8 - 12 m/min.	8 - 15 m/min.
Double chamber tunnel		-		8 - 20 m/min.
Installed power - kW				
Machine + Standard tunnel	4.5 + 17	4.5 + 22	4.5 + 38	11 + 18
Machine + Double chamber tunnel		-		11 + 27

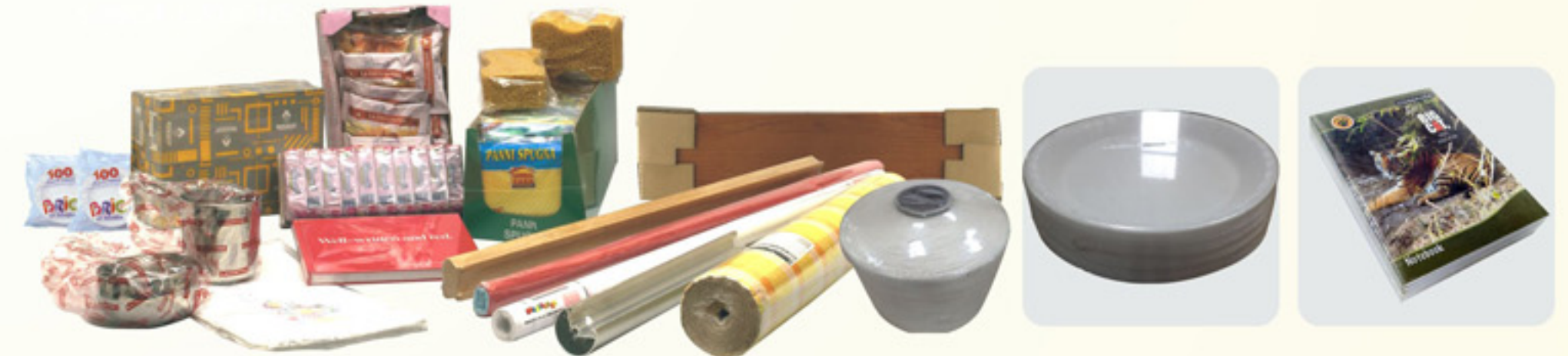

		Sally 5	Sally 8	Sally 12	Sally 5/HS
Minimum dimension	A	150 mm	150 mm	150 mm	150 mm
	B	25 mm	80 mm	300 mm	25 mm
	H	25 mm	30 mm	50 mm	25 mm
Maximum dimension	A	6000 mm	6000 mm	6000 mm	6000 mm
	B	380 mm	600 mm	1000 mm	380 mm
	H	300 mm	370 mm	400 mm	300 mm
Maximum B+H		650 mm	950 mm	1200 mm	650 mm

Product dimensions:

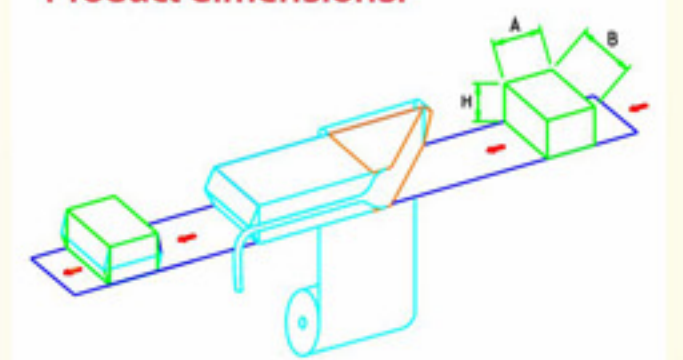



TRAYMASTER

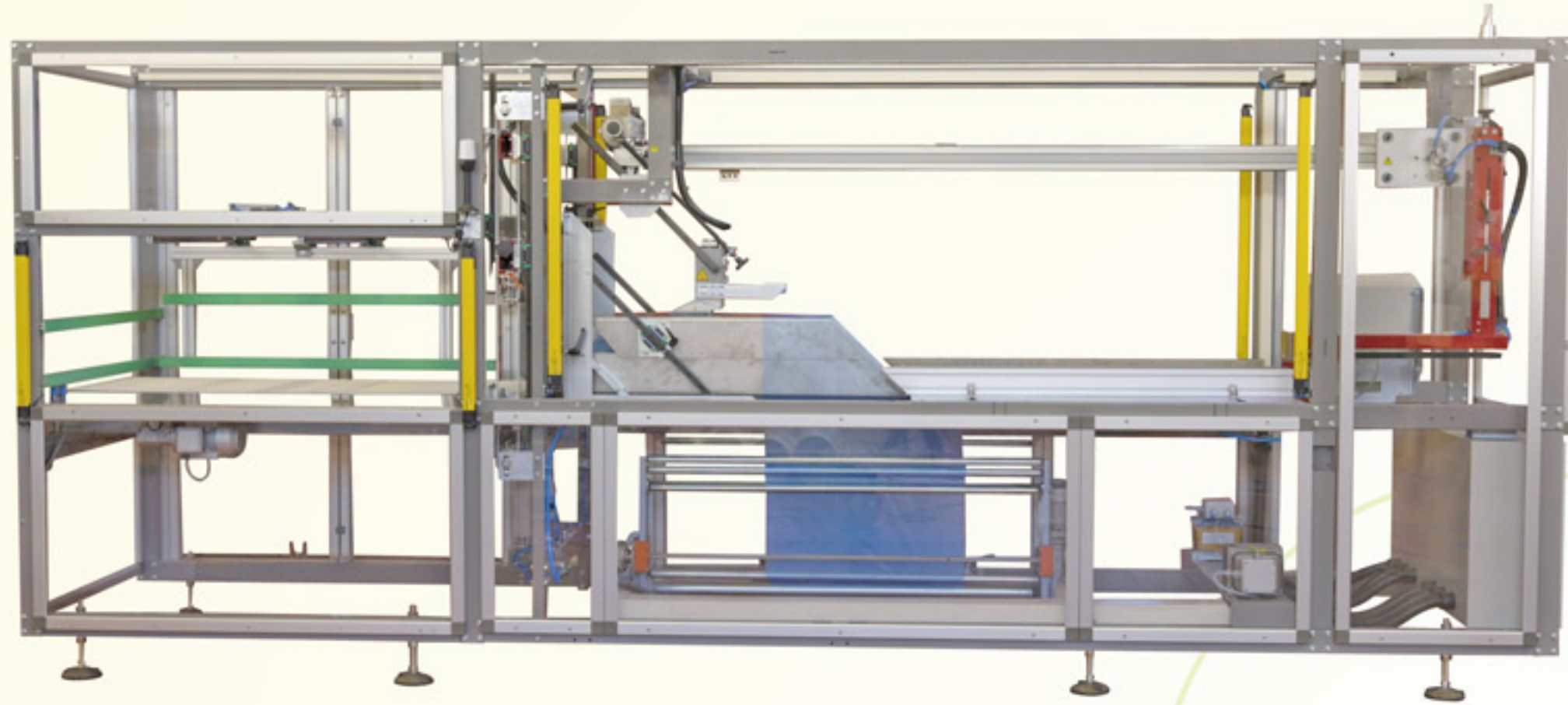

Semi-automatic bagging machine designed for EPS, ABS, P.E. or P.P, thermoformed trays. Products are manually loaded by an operator.

- ✓ Saves 15% film for each package compared to pre-made bags
- ✓ Minimum thickness packing material for handling a tight final package
- ✓ Best use of floor with logical product flow
- ✓ Improved production efficiency
- ✓ This automated line substitutes 10 manual operators in each production shift.

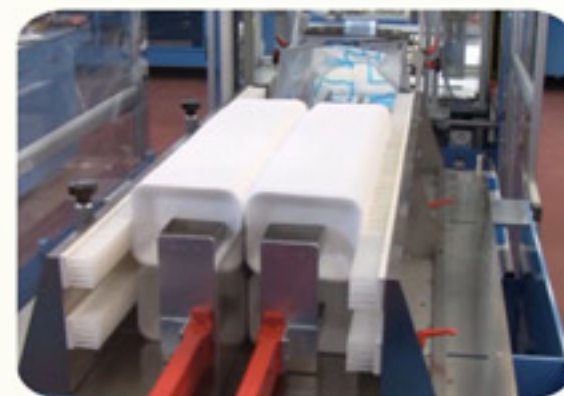
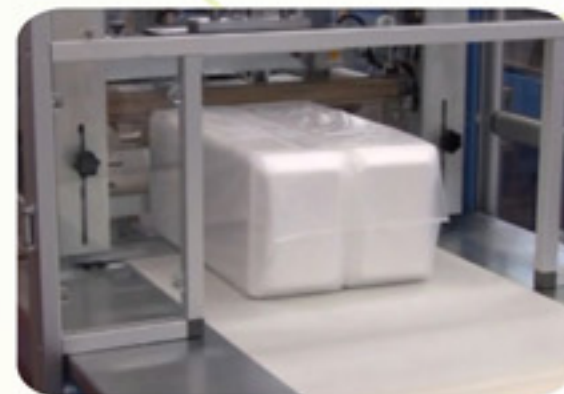

SHRINK WRAPPING MACHINES

Installed power (kW)	4.5
Compressed air consumption (6 bars)	40 NI / cycle
Type of film	PE, HMHDPE, LDPE
Max. Ø of film reel (mm)	400
Film thickness (µ)	13 - 80
Min. (A x B x H) (mm)	250 x 130 x 130
Max. (A x B x H) (mm)	1250 x 600 x 430

Product dimensions:

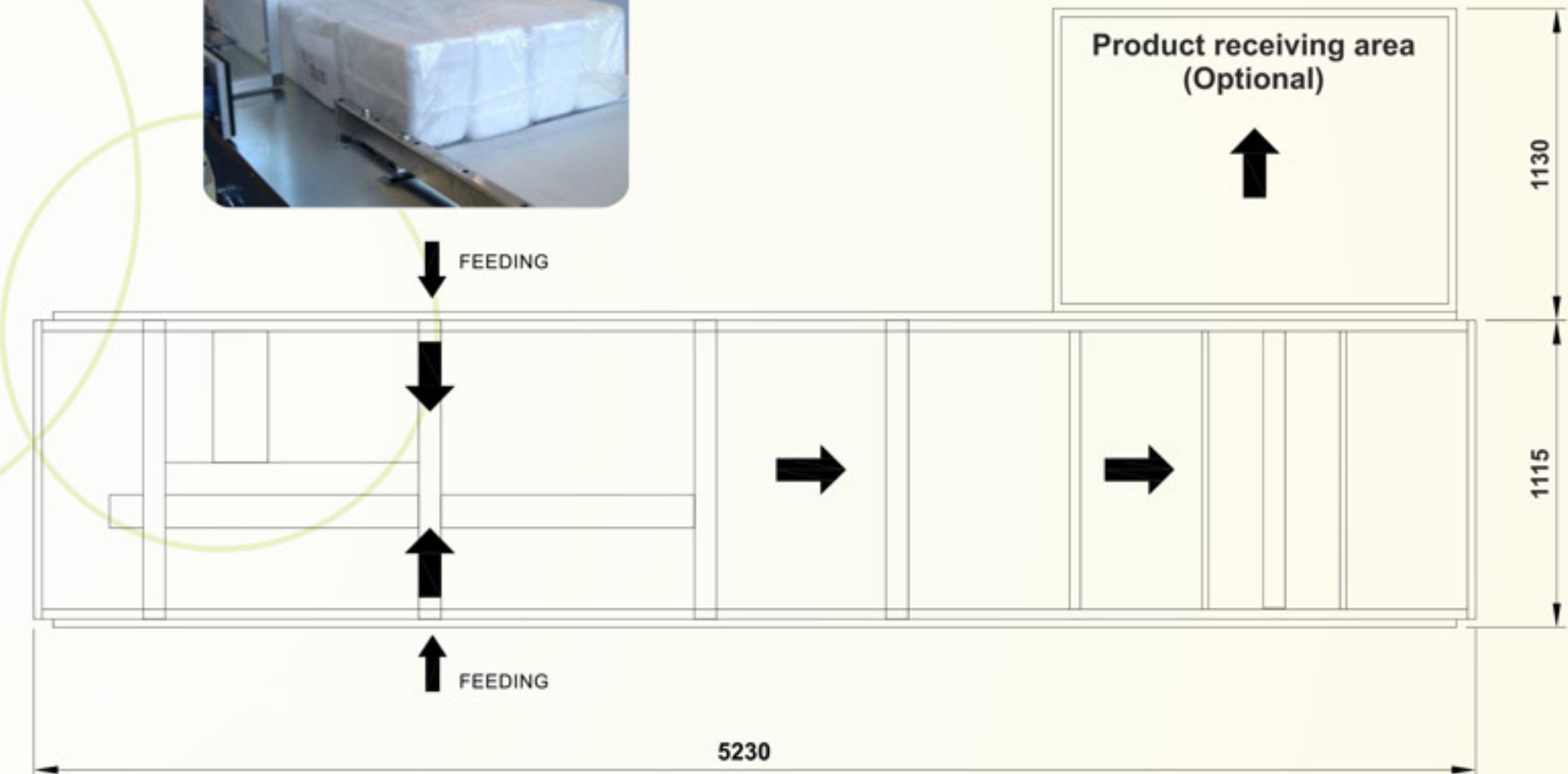
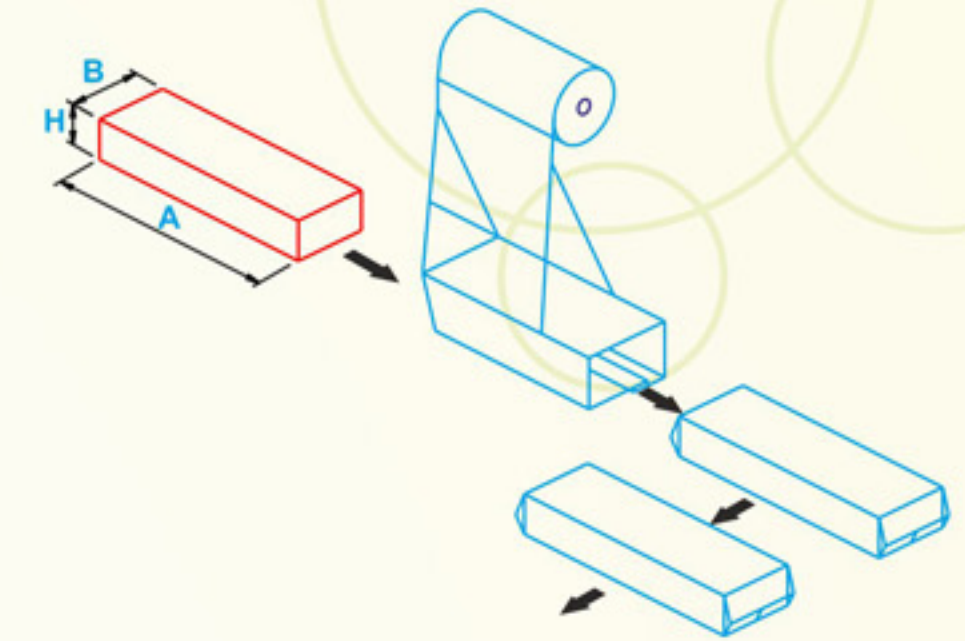

Note: All dimensions are in mm





OUR DEPARTMENTS



Marketing: Marketing & after-sales service are part of prime importance to keep customer satisfaction at its peak



Design: Highly qualified - Italy trained engineers see that Italian design suits our Indian requirements



Documentation: Well equipped documentation division for design, purchase, quality control and accounting.



CNC Machines: Equipped with CNC machines to manufacture precision components enables to pass through stringent quality control tests & keep higher production



Fabrication: Fully equipped fabrication with latest equipments and processes is the secret of manufacturing excellence



Quality Control: Tools & Gauges, qualified engineers, latest equipments enable to pass stringent quality control tests.



Service: Skilled team of Service Technical staffs ready to support for set-up and Technical intervention on site.



Packing: Well equipped packing division to maintain safety and security of components and spares



ItaIndia Pack Plus

An initiative by Penguin to bring world class technology to India for the manufacture of WRAPPING MACHINES.

Penguin's Make in India program intensified much ahead of its time when it tied up with MacDue, Bologna, Italy in a joint-venture deal that saw the formation of **ITALINDIA PACKPLUS PRIVATE LIMITED** in its home turf; Coimbatore. With **MacDue** bringing to the table International standards design and **Penguin** providing the manufacturing assets, this formidable association was promoted to manufacture Shrink Wrapping machines for world markets. The first step to this venture took shape with the inauguration of the **ITALINDIA** factory in Coimbatore by Dr. Fiorenzo Donetti on the 27th of January 2010 with nothing stopping its progress and continued success till date.



Italindia Packplus Factory

We thank our major customers



(A Joint Venture of Mac Due, Italy & Penguin Engineers, India)

ITALINDIA PACKPLUS PVT. LTD.

93, Kondayampalayam
 Vaiyampalayam Post
 Coimbatore - 641 110. Tamil Nadu INDIA
 Tel: +91 94898 43640; +91 94891 43037



✉ info@italindia.in
 sales@italindia.in

🌐 www.italindia.in